

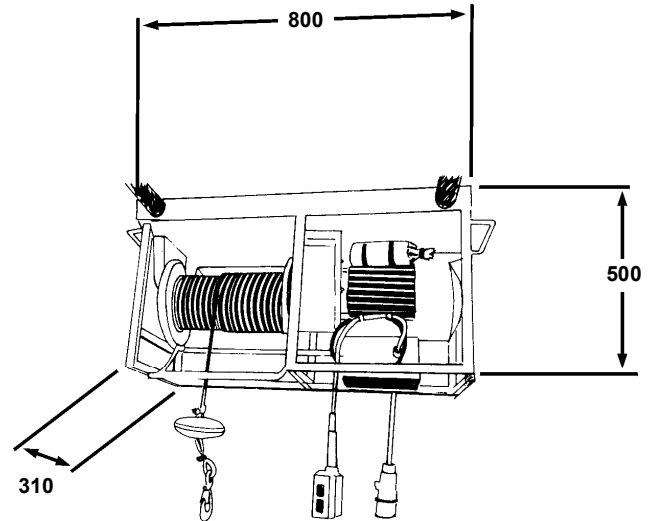

# BETA LD600 GANTRY HOIST

HOIST SPECIFICATIONS	
<b>Payload</b>	600kg
<b>Maximum Lifting Height</b>	40m
<b>Speed</b>	12.5m/min
<b>Voltage</b>	110V single phase
<b>Power Cont. Duty</b>	1.9kW
<b>Power Consumption</b>	3.52kVA
<b>Power Supply Fuses (HRC)</b>	32A
<b>Unit Weight</b>	62kg
<b>Installation Type</b>	
Static	✓
Scaffold Winch	✗
Runway Beam	✗
Ground Based	✗



## Accessories Available from London Hoist

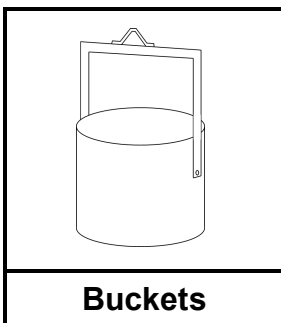

**Buckets**

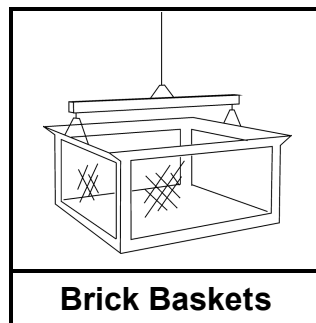

**Brick Baskets**

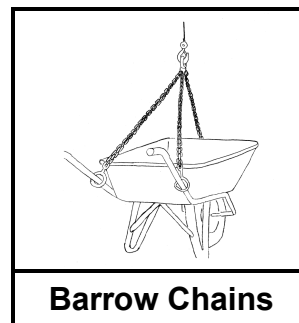

**Barrow Chains**



**Webbing Slings**



LONDON  
HOIST  
LTD

RIFLE STREET - LONDON - E14 6PB  
TEL : 0207 5384833 - FAX : 0207 5153593  
www.londonhoist.co.uk - info@londonhoist.co.uk